

A tradition of reliability...

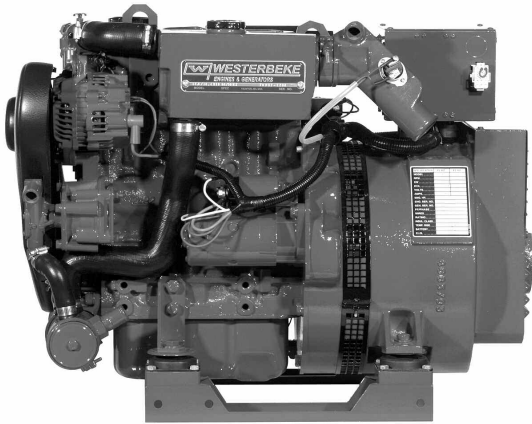

11.0/8.8 BTDB Diesel Generator

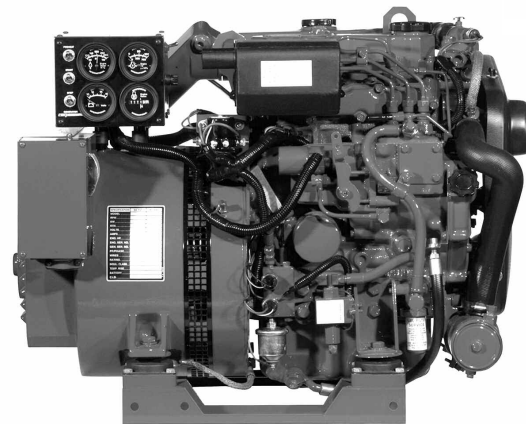

11.0/8.8 BTDB Diesel Generator

Quiet and Compact

Smooth and quiet operation is provided by a low-speed, 3-cylinder engine with tuned air intake silencer and four point anti-vibration mounts. A unique AC generator with short, "pancake" design and an engine with smartly fit components result in a highly compact generator set for the most demanding installations.

Lightweight and Reliable

Powered by a lightweight rugged "industrial" engine, this model continues to support the strong record of reliability Westerbeke has built supplying product to the United States Navy and Coast Guard as well as commercial vessels and pleasure craft world-wide.

Longer Life and Easier Maintenance

The engine operates at a low 1800 or 1500-rpm and is fresh water cooled, via heat exchanger, for longevity. The generator windings are NEMA class "H" insulated and double vacuum epoxy impregnated to increase protection against the harsh marine environment. Easy access to most servicing points and individually removable top and side panels of the optional sound enclosure contribute to easier maintenance.

Full Torque, Power Take-Off Interface

A customer sourced, electric clutch and hydraulic pump can be mounted to the full torque, power take-off interface for use with such items as bow or stern thrusters, compressors, winches and emergency "get home" systems.

Five Year Limited Warranty

This generator set is backed by Westerbeke's 5-year limited warranty. The presence of Westerbeke in over 65 countries around the world provides customers with easy access to parts, service and technical support world-wide. Established in 1937, Westerbeke is committed to providing its customers with quality products and unequaled after sales support.

Standard Features

- Instrument panel and safety stop switch
- Remote start-stop plug-in connection
- Electronic governing
- Extra oil pressure switch for remote signal or control functions
- Safety shut-downs: high coolant temperature, low oil pressure, high exhaust temperature
- A.C. circuit breaker (single phase)
- 50 amp battery charging alternator
- Power take-off interface
- Self-bleeding fuel system
- Fresh water cooling and coolant recovery tank
- 45 degree water injected exhaust elbow
- Gear driven raw water pump
- Tuned air intake silencer
- Vibration mounts - fail safe rubber type
- Lube oil drain hose and drip tray
- Oil fill - top and side
- Belt guard
- Operators' manual and parts list
- Complies with U.S. EPA regulations

Optional Sound Guard SST



Generator Dimensions with Sound Guard SST

Length	31.5" (800 mm)	36.1" (916 mm)
Width	19.1" (485 mm)	23.2" (589 mm)
Height	24.0" (610 mm)	25.3" (643 mm)
Weight	513 lbs. (233 kilos)	595 lbs. (270 kilos)

Generator Design

DESIGN: Brushless, four pole, revolving field, power takeoff.
VOLTAGE REGULATION: Standard +/- 5% no load to full load.
FREQUENCY REGULATION: .5 Hz (.60%) no load to full load.
INSULATION: Class "H", as defined by NEMA MG1-1.65.

TEMPERATURE RISE: Within NEMA MG1-22.40 definition when operating at full load.

COOLING: Cast centrifugal blower, direct connected.

ELECTROMAGNETIC INTERFERENCE LEVEL: Exceeds requirements for most marine radio-telephones and standard TVs.

Model	Electrical Characteristics					Ratings		Engine	
	Volts	Amps	Hertz	Phase	Wire	Power Factor	KW	RPM	Start
11.0 BTDB-614	120/240	91.7/45.8	60	1	4	1.0	11.0	1800	Remote
8.8 BTDB-514	230	38.3	50	1	4	1.0	8.8	1500	Remote

Three phase units, 50 & 60 Hz, are available in these ratings.

Generator field adjustable to 50 or 60 Hz.

Specifications

Number of cylinders	3 Cylinder vertical in-line	
Type	4 cycle	
Displacement	80.43 cu. in. (1.318 liter)	
Bore and stroke	3.07" x 3.62" (78 mm x 92 mm)	
Compression ratio	22:1	
Rated rpm @ 60/50Hz	1800/1500	
HP @ 1800/1500 rpm	18.4/14.7	
Maximum angle of operation	15° Continuous	
Exhaust elbow connection	2.0" OD (50.8mm)	
Raw water connection	1.0" OD (25.4mm)	
Dry weight	513 lbs. (232.7 kilos)	
Combustion system	Swirl type	
Aspiration	Naturally aspirated	
Lubrication system	Forced lubrication by gear pump	
Cooling system	5 quarts (4.7 liters)	
Starting aid	12 volt sheathed type glow plug	
Fuel consumption (approx.)	1800 rpm	1500 rpm
100% load GPH (LPH)	1.18 (4.5)	0.95 (3.6)
75% load GPH (LPH)	0.91 (3.5)	0.73 (2.8)
50% load GPH (LPH)	0.70 (2.7)	0.55 (2.1)
25% load GPH (LPH)	0.51 (1.9)	0.39 (1.5)
Fuel injection pump	Bosch type	
Governor	Electronic	
Injectors	Throttle type	
Fuel Filter	Primary and secondary	
Fuel transfer pump	12 Volt DC electric type	
Fuel supply and return piping	1/4" ID (6.35 mm) minimum	
	3/8" ID (9.52 mm) maximum	

Lube oil filter	Full flow, spin-on element
Lubricant capacity	4 quarts (3.8 liters)
Starting motor	12 volt, solenoid actuated
Battery charging alternator	50 ampere (12 volts)
Cold cranking amps	240 amps @ 69 degrees F
Electrical system	12 volts DC, negative ground

Construction-Engine Components

Cylinder head	Cast Iron
Cylinder block	Cast Iron
Crankshaft	Forged crankshaft, four main bearings
Valves	Overhead rotating type
Fuel System	Self-bleeding
Intake system	Tuned intake silencer for maximum noise reduction
Cooling system	Fresh water-cooled with shell and tube type heat exchanger
Exhaust manifold	Cast aluminum, fresh water-cooled

Optional Equipment

- Dual station engine instrument panel with senders
- Remote start/stop panel
- Remote lube oil filter kit
- Dipstick extension kit
- Sound Guard SST
- Hydro-hush muffler and fittings
- Fuel/water separator
- Anti-siphon valve with 1 inch stainless steel loop
- Ship-to-shore switch
- Power take-off adapter
- "A" on board spare parts kit; "B" extended cruising spare parts kit
- Technical Manual
- Generator set available painted white upon request (standard red)

Dimensions

Inches (millimeters)

