

Dimensional Drawing
M944W3 - 30 kW/26 kW

AC Output¹	
30 kW	60 Hz, 1800 RPM, 1 Ph, 1.0 PF, 120-240 V/125 A, 120 V/250 A
26 kW	50 Hz, 1500 RPM, 1 Ph, 1.0 PF, 220 V/118 A
Optional	Three Phase with 0.8 PF
Voltage regulation	±1%
Lugger L944 Engine	
Type	Vertical inline 4 cylinder diesel
Displacement	203 in ³ (3.3 ltr)
Bore/Stroke	3.70/4.72 in (94/120 mm)
HP @ RPM	49.0/1800 39.0/1500
Approximate fuel use	
1800 RPM @ full load ²	2.80 gph (9.80 lph)
1800 RPM @ half load ²	1.50 gph (5.30 lph)
1500 RPM @ full load ²	2.30 gph (7.41 lph)
1500 RPM @ half load ²	1.20 gph (4.16 lph)
Installation Data & Weight	
Wet exhaust elbow	3 inch (76 mm) OD
Raw water inlet	3/4 inch (19 mm) OD
Fuel inlet and return	1/4 inch NPT
Approximate dry weight	1351 lbs (604 kg)

1. Based on SAE J1995 and ISO 3046.
2. Actual fuel consumption will vary depending on operating conditions

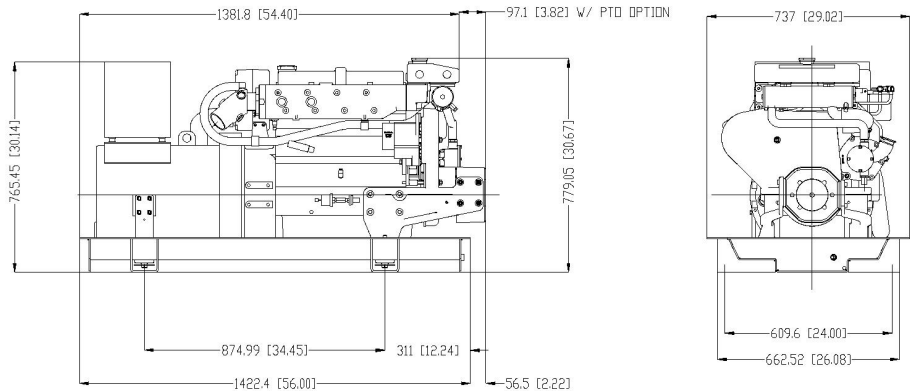

M944W3 Overall Dimensions L x W x H: 56.0 x 29.0 x 30.7 inch (1422 x 737 x 779 mm)
Sound Enclosure Dimensions L x W x H: 56.0 x 29.0 x 31.5 inch (1423 x 737 x 800 mm)
Sound Enclosure Weight: 158 lbs. (72 kg)

Dimensions given in inches (mm). Dimensions subject to change without notice.
 Contact dealer or visit www.northern-lights.com for most current installation drawings.

M944W3 Features and Benefits
Engine Block

- Four cycle, 4 cylinder, liquid cooled, naturally aspirated, overhead valve diesel.
- Induction hardened crankshaft. Forged carbon steel - stronger than cast iron.
- Helical cut and ground, carbon steel timing and PTO gears reduce noise.
- Cross flow head for efficient breathing.

Cooling System

- Freshwater cooling system in heat exchanger or keel cooled configuration.
- Large, easy-fill single-piece exhaust manifold is freshwater cooled for safety. No hot, dry risers. Fewer troublesome hoses and gaskets. Cast iron to resist corrosion and electrolysis.
- Zinc anode electrolysis protection.
- Heat exchanger cooling is standard. Cupro-nickel tube-type heat exchanger has removable ends for easy cleaning. Rubber impeller seawater pump of bronze and stainless steel is gear driven; no belt.

Fuel System

- IDI with glow plugs.
- Bosch-type in-line injection pump with 5% mechanical governor for close AC frequency control.
- Pintle injectors.
- Mechanical lift pump with hand primer. No electric pump to fail.
- Large spin-on fuel filter.
- Flexible fuel lines routed to base.
- Stop solenoid controls the fuel rack, not the throttle, to eliminate speed variances and linkage problems.

Intake and Exhaust

- Washable air cleaner in cast intake manifold reduces intake noise.
- Cast iron, wet exhaust elbow for safety.

Lubrication System

- Full flow, spin-on oil filter with bypass.
- 10.5 qt (10.0 ltr) center well oil pan. 250 hour oil change intervals.
- Oil drain for quick, clean oil changes.

DC Electrical System

- DC system uses reliable relays instead of an unrepairable printed circuit board.
- 12 volt starter motor and battery charging alternator with regulator and belt guard.
- Standard panel: Remote mount S-3C has hour meter, stop-start switch with run light and preheat switch. Gauges for oil pressure, coolant temp and DC voltage. Safety shutdowns for low oil pressure, high coolant temp and high exhaust temp.
- Expandable to six panels up to 110 feet from the set.

- 20 foot (6m) plug-in panel harness lets you mount your panel anywhere onboard.

AC Generator

- Northern Lights, direct coupled, brushless AC generator is maintenance free. 4 lead, 1 phase, 50 or 60 Hz output standard. 12 wire, 3 phase optional. Conservative heat rise rating: 95°C/50°C ambient.
- Automatic voltage regulator (AVR) is powered by dedicated AC winding for true 300% short circuit capability and circuit breaker protection. Quick ±1% RMS no load to full load voltage regulation.
- Generator features high quality, Class "H" epoxy insulation, accessible diodes, over-sized bearings and junction box for wiring.

Special Equipment

- Welded steel base frame with drip pan.
- Four platform mounts isolate vibration.
- Belt guard protects operator.
- White, long-life polyurethane paint.
- Operator's and parts manuals standard.

Classification Standards

- Consult factory for details.
- Available for non-US flagged vessels only.



www.northern-lights.com

Dealer

4420 14th Ave. NW., Seattle WA 98107
 Tel: 206-789-3880 • 1-800-762-0165 • Fax: 206-782-5455

Information and dimensions subject to change without notice.

Northern Lights and Lugger are registered trademarks of Northern Lights, Inc.

© 2014 All rights reserved. Litho USA. S108 2/14