

Marine Generator Set

Generator Features

- Engine is Environmental Protection Agency (EPA) Marine Tier III compliant
- Superior Kohler Fast-Response® PMG excitation system
- Remote control connector
- Class H insulation
- Reconnectable voltage
- One- or three-phase reconnectable alternator
- Voltage regulation of 2%
- Frequency regulation of 0.5%

Optional Accessories

- Sound Shield
- Remote digital display
- Isolated ground system (12- or 24-volt), standard
- Circuit breakers

Optional Agency Type Approvals

- Lloyd's Register
- Det Norske Veritas (DNV)
- Bureau Veritas (BV)
- American Bureau of Shipping (ABS)



Generator Weights and Dimensions

| | Without Sound Shield | With Sound Shield |
|------------------|----------------------|-------------------|
| Weight, kg (lb.) | | |
| Wet | 2067 (4558) | 2147 (4733) |
| Dry | 2006 (4422) | 2085 (4597) |
| Length, mm (in.) | 2490 (98.04) | 2661 (104.76) |
| Width, mm (in.) | 970 (38.19) | 1048 (41.26) |
| Height, mm (in.) | 1086 (42.76) | 1174 (46.21) |

See the drawings on the last page for detailed dimensions.

Generator Ratings (Prime)

| Model | Generator (Alternator) | Voltage | Hz | Ph | Amps | Rated kW/kVA |
|-------------------|------------------------|---------|----|----|------|--------------|
| 200EOZDJ (4UA10) | | 120/208 | 60 | 3 | 695 | 200.0/250.0 |
| | | 120/240 | 60 | 3 | 602 | 200.0/250.0 |
| | | 127/220 | 60 | 3 | 657 | 200.0/250.0 |
| | | 139/240 | 60 | 3 | 602 | 200.0/250.0 |
| | | 277/480 | 60 | 3 | 301 | 200.0/250.0 |
| 175EFOZDJ (4UA10) | | 110/190 | 50 | 3 | 666 | 175.0/218.7 |
| | | 110/220 | 50 | 3 | 575 | 175.0/218.7 |
| | | 220/380 | 50 | 3 | 333 | 175.0/218.7 |
| | | 230/400 | 50 | 3 | 316 | 175.0/218.7 |
| | | 240/416 | 50 | 3 | 304 | 175.0/218.7 |

RATINGS: Ratings per ISO 3046, ISO 8528-1, and Kohler ISO rating guideline 2.14. Obtain technical information bulletin (TIB-101) on ratings guidelines for complete ratings definitions. Availability is subject to change without notice. Kohler Co. reserves the right to change the design or specifications without notice and without any obligation or liability whatsoever. Contact your local Kohler generator set distributor for availability.

10% overload capacity one hour in twelve hours.

Application Data

Engine

| Engine Specifications | 60 Hz | 50 Hz |
|--------------------------------|------------------------------|-------|
| Type | Inline, 4-cycle | |
| Number of cylinders | 6 | |
| Firing order | 1-5-3-6-2-4 | |
| Aspiration | Turbocharged and aftercooled | |
| Displacement, L (cu. in.) | 9.0 (549) | |
| Bore and stroke, mm (in.) | 118 x 136 (4.6 x 5.4) | |
| Compression ratio | 16.3:1 | |
| Combustion system | Direct injection | |
| Rated rpm | 1800 | 1500 |
| Maximum power at rated rpm, HP | 298 | 261 |
| Cylinder block material | Cast iron | |
| Cylinder head material | Cast iron | |
| Piston rings | 2 compression/1 oil | |
| Crankshaft material | Forged steel | |
| Connecting rod material | Forged steel | |
| Governor type | Electronic | |

Engine Electrical

| Engine Electrical System | 60 Hz | 50 Hz |
|--|---------------------|-------|
| Battery, voltage | 12- or 24-volt spec | |
| Battery, charging (12 volt) | 90 amp | |
| Battery, charging (24 volt) | 60 amp | |
| Battery, recommendation (minimum, 12 volt) | 1100 CCA | |
| Battery, recommendation (minimum, 24 volt) | 750 CCA | |
| Starter motor | Gear-reduction type | |

Cooling

| Cooling System | 60 Hz | 50 Hz |
|--|------------------------|-------------|
| Capacity, L (U.S. qt.) (approx.) | 30 (31) | |
| Cooling type | Heat exchanger | |
| Seawater pump type | John Deere gear driven | |
| Seawater pump suction lift, maximum, m (ft.) | 3.0 (10.0) | |
| Heat rejected to cooling water at rated kW, wet exhaust, kW (Btu/min.) | 169 (9619) | 182 (10359) |
| Engine water pump flow, Lpm (gpm) | 216 (57) | 235 (62) |
| Seawater pump flow, Lpm (gpm) | 352 (93) | 299 (79) |

Fuel

| Fuel System | 60 Hz | 50 Hz |
|--|---|-------|
| Fuel recommendation | Diesel fuel specified to EN 590 or ASTM D975 | |
| Fuel shutoff solenoid | Electric | |
| Fuel injection pump | Nippodenso High Pressure Common Rail (HPCR), electronic | |
| Fuel pump priming | Manual | |
| Maximum recommended fuel lift, m (ft.) | 3.0 (10.0) | |

Lubrication

| Lubricating System | 60 Hz | 50 Hz |
|--|---------------|-------|
| Oil pan capacity with filter, L (U.S. qt.) | 31.94 (33.75) | |
| Type | Pressure | |

Operation Requirements

| Air Requirements | 60 Hz | 50 Hz |
|--|-------------|-------------|
| Engine combustion air requirements, m ³ /min. (cfm) | 15.7 (554) | 11.6 (410) |
| Max. air intake restriction, kPa (in. H ₂ O) | 6.25 (25) | 6.25 (25) |
| Cooling air required for generator set at 50°C (122°F) ambient, m ³ /min. (cfm) | 91.4 (3000) | 76.2 (2500) |
| Exhaust flow, m ³ /min. (cfm) | 49 (1713) | 40 (1409) |
| Exhaust temp., °C (°F) | 493 (919) | 453 (847) |
| Max. allowed exhaust backpressure, kPa (in. H ₂ O) | 7.5 (30) | 7.5 (30) |

| Fuel Consumption | 60 Hz | 50 Hz |
|------------------------------------|-------------|-------------|
| Diesel, Lph (gph) at % load | | |
| 100% | 59.9 (15.8) | 53.1 (14.0) |
| 75% | 44.5 (11.7) | 38.0 (10.0) |
| 50% | 34.8 (9.2) | 25.5 (6.7) |
| 25% | 18.2 (4.8) | 14.3 (3.8) |

Engine Features

- One-side serviceability of fuel system, lubrication system, and air cleaner
- Low oil pressure cutout
- High water temperature cutout
- Loss of coolant cutout
- Overcrank cutout
- Belt guard
- Optional digital display
- Disposable oil filter
- Extended oil drain
- PTO options: 12- or 24-volt electric clutch

Controller Features

- A graphical display and pushbutton/rotary selector dial provide easy, local data access.
- Measurements are selectable in metric or English units.
- The controller supports Modbus® protocol with serial bus (RS-485) or Ethernet networks.
- Scrolling display shows critical data at a glance.
- Graphical display of power metering (kW, kVA, V, I, PF, and VAR).
- Integrated hybrid voltage regulator providing ±0.5% regulation.
- Built-in alternator thermal overload protection.

Modbus® is a registered trademark of Schneider Electric.

Decision-Maker® 3500 Paralleling Controller



Provides advanced control, system monitoring, and system diagnostics for optimum performance and compatibility. The Decision-Maker® 3500 controller uses a patented hybrid voltage regulator and unique software logic to manage alternator thermal overload protection features normally requiring additional hardware. Additional features include:

- **AC Output Voltage Regulator Adjustment.** The voltage adjustment provides a maximum adjustment of $\pm 10\%$ of the system voltage.
- **Alarm Silence.** The controller can be set up to silence the alarm horn only when in the AUTO mode for NFPA-110 application or Always for user convenience.
- **Alternator Protection.** The controller provides generator set overload and short circuit protection matched to each alternator for the particular voltage/phase configuration.
- **Automatic Restart.** The controller automatic restart feature initiates the start routine and re crank after a failed start attempt.
- **Cyclic Cranking.** The controller has programmable cyclic cranking.
- **ECM Diagnostics.** The controller displays engine ECM fault code descriptions to help in engine troubleshooting.
- **Engine Start Aid.** The configurable starting aid feature provides customized control for an optional engine starting aid.
- **Event Logging.** The controller keeps a record (up to 1000 entries) for warning and shutdown faults. This fault information becomes a stored record of system events and can be reset.
- **Historical Data Logging.** Total number of successful starts of the generator is recorded and displayed.
- **Integrated Hybrid Voltage Regulator.** The voltage regulator provides $\pm 0.5\%$ no-load to full-load RMS voltage regulation with three-phase sensing.
- **Lamp Test.** Press the alarm silence/lamp test button to verify functionality of the indicator lights.
- **LCD Display.** Adjustable contrast for improving visibility.
- **Measurement Units.** The controller provides selection of English or metric displays.
- **Power Metering.** Controller graphical display provides voltage, current, power factor, kW, kVA, and kVAR.
- **Programming Access (USB).** Provides software upgrades and diagnostics with PC software tools.
- **Remote Reset.** The remote reset function supports acknowledging and resetting faults and allows restarting of the generator set without going to the master control switch off/reset position.
- **Run Time Hourmeter.** The generator set run time is displayed.
- **Time Delay Engine Cooldown (TDEC).** The TDEC provides a time delay before the generator set shuts down.
- **Time Delay Engine Start (TDES).** The TDES provides a time delay before the generator set starts.
- **Voltage Selection Menu.** This menu provides the capability to switch the generator output voltage. NOTE: Generator set output leads may require reconnection.
- **Paralleling Functions:**
 - Bus sensing
 - First on logic
 - Synchronizing
 - Communication based isochronous load sharing
 - Droop load sharing
 - External controlled load sharing via analog bias signals

Alternator Specifications

Alternator Specifications

| Specifications | Alternator |
|--|---|
| Manufacturer | Kohler |
| Type | 4-pole, rotating-field |
| Exciter type | Brushless, permanent-magnet, Fast-Response® |
| Number of leads | 12, reconnectable |
| Voltage regulator | Solid state, volts/Hz |
| Insulation: NEMA MG1-1.66 | |
| Material | Class H |
| Temperature rise | 90°C |
| Bearing: number, type | 1, sealed |
| Coupling | Flexible disc |
| Amortisseur windings | Full |
| Voltage regulation, no load to full load | 2% |
| One-step load acceptance per NFPA 110 | 100% of rating |
| Peak motor starting kVA—4UA10 | 785 |

Alternator Features

- The generator complies with NEMA, IEEE, and ANSI standards for temperature rise.
- The alternator uses a permanent-magnet, Fast-Response® excitation system.
- The alternator has a two-thirds pitch stator and skewed rotor.
- The generator has a solid-state, volts-per-hertz voltage regulator.
- The brushless, synchronous generator is broadrange and reconnectable.
- The windings are vacuum-impregnated with epoxy varnish for dependability and long life.
- The generator is capable of sustained line-to-neutral short-circuit current of up to 300% of the rated current for up to 2 seconds. (IEC 60092-301 short-circuit performance.)

Optional Accessories

- Modular sound shield manufactured with 5052-H32 aluminum in powder-coated Matterhorn white
- Circuit breakers
- Remote digital display
- Remote monitoring, start/stop panel with wiring harness for connection to the generator controller
- Duplex fuel filter
- Siphon break
- Remote connection/extension harness
- Oil level indicator (high/low)
- Low coolant level indicator
- Isolated ground system (12- or 24-volt), standard
- Electric front clutch power takeoff (PTO) 12- or 24- volt

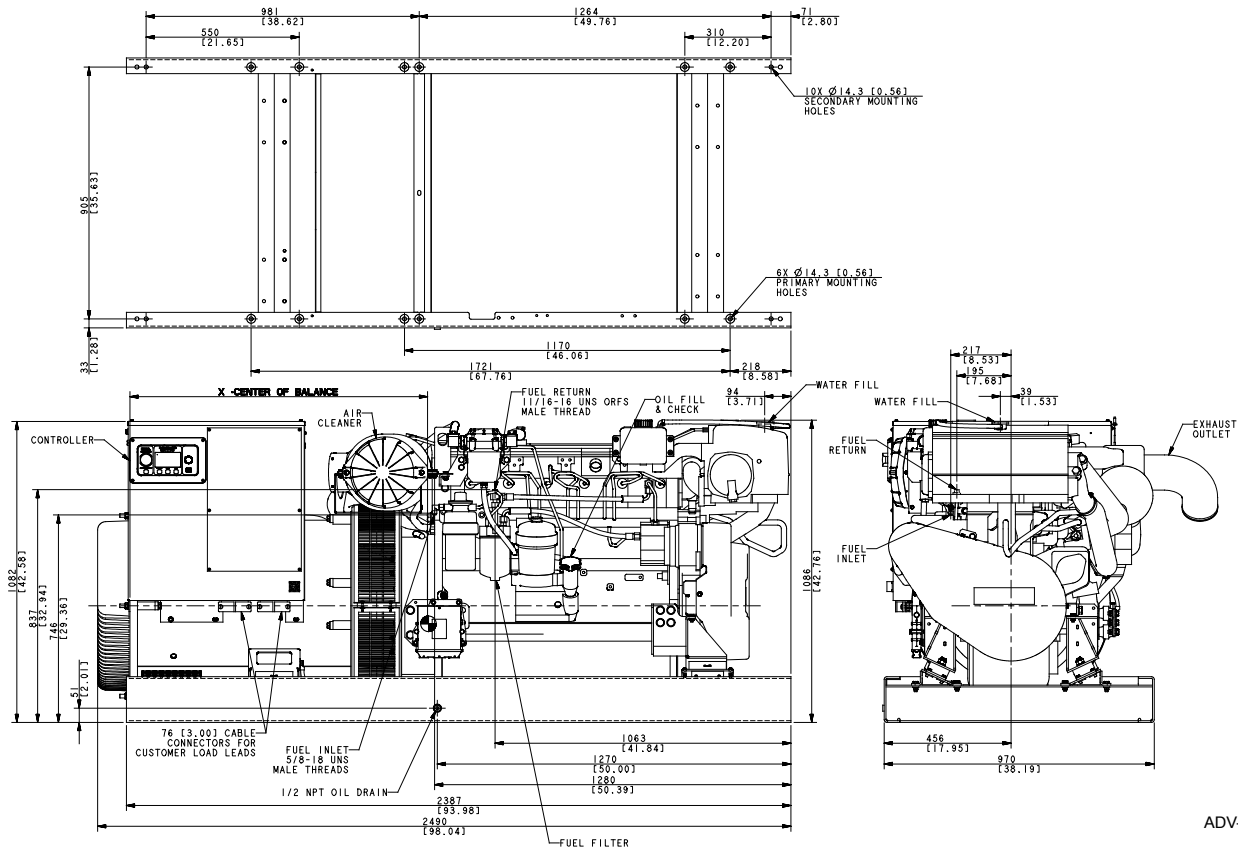

ADV-8747-

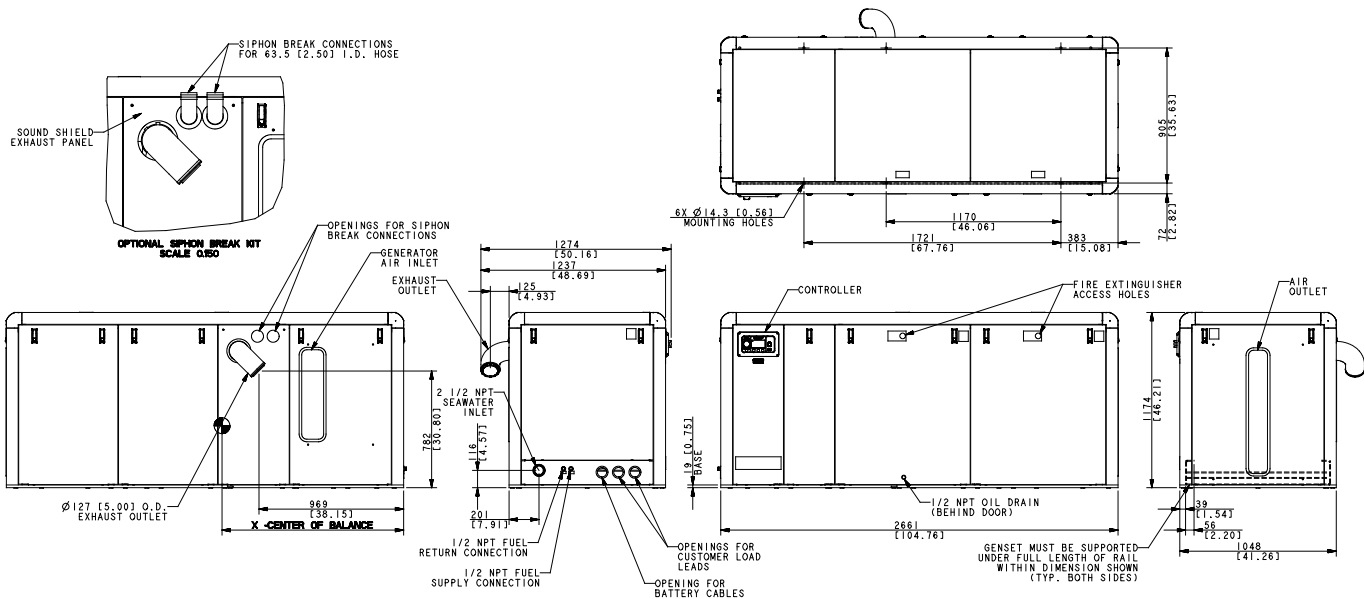

ADV-8748-

DISTRIBUTED BY:

NOTE: Dimensions are shown in mm [in.].
 NOTE: This drawing is provided for reference only and is not intended for installation planning. Contact your local distributor for more detailed information.